

Product Data Sheet

OS ITNO	Hilti ITNO	Product name	Material
1300293	2257312	Starter Mekano 50-2T ST-WD-200 HDG	Hot dip galvanized



Welded starter bracket for Mekano channels 50-2 and 50-2T. Also used for piping installations when combined with triangle channel with square holes.

The starter bracket is partly galvanized. Approx. 40mm is left free from zinc galvanizing to allow the bracket to be welded to the structure.

Additional information: Available in three lengths: 125mm, 200mm and 300mm.

Note: Starter bracket in 125mm length is not suitable for Norsok painting regulations.

Note for HDG material: These starter brackets are partly galvanized. Approx. 20mm for type 125 and 40mm for type 200 and 300 is left free from zinc galvanizing to allow the bracket to be welded to the structure.

Note for CS material 300: Neither edges nor bolt holes are prepared for surface treatment - must be carried out on site as necessary.

Characteristics

Name	Value
Weight (kg)	1.010
T Material Thickness (mm)	6.0
X (mm)	61
Y (mm)	200
Z (mm)	61
A Hole Size (mm)	11x35
B Hole Size (mm)	Ø25
CC (mm)	50
G Deburring (mm)	90

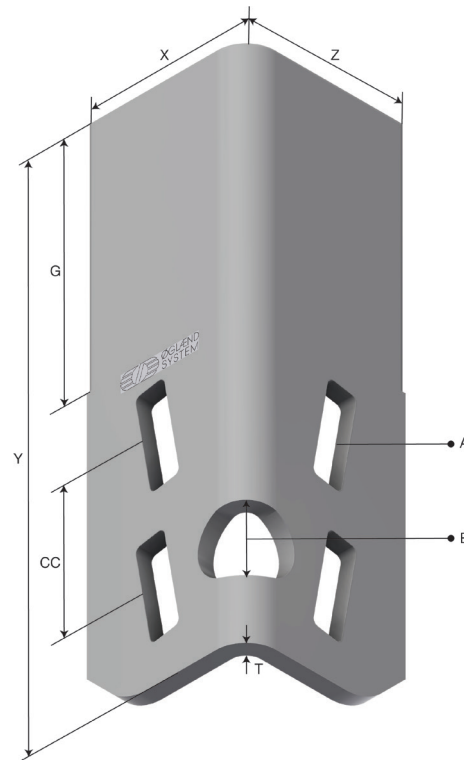

Product images are a general representation of the product design however some variances may occur.

Product packaging information

F-PAK GTIN	Single piece	
D-PAK GTIN		