

# KRC Damplamper

## Metallhalogen

Rørform klar, ellipsoid klar og  
ellipsoid matt 400W



## Produktinformasjon

Høy lysstyrke, høykvalitets hvitt lys med god fargegjengivelse og høyt lysutbytte gjør Tungsram Metallhalogendamplamper egnet til mange næringsbygg og industri, spesielt i områder med høye takhøyder.

## Bruksområder

- Kontor
- Fritidsområder
- Varehus
- Lagerbygg
- Industribygg
- Arkitektonisk belysning
- Flomlys
- Parkingsplass og garasjer

## Samsvarer med IEC Standarder

Alle KRC damplamper samsvarer med IEC62035.

## Korte data:

	Rørform klar		Ellipsoid matt	
	93102172**	93102246 / EL.NR. 38 222 70	93102177**	93102161**
Bestillingsnr	93102172**	93102246 / EL.NR. 38 222 70	93102177**	93102161**
Produktbeskrivelse	KRC400/T/UVC/H/960/E40 TU	KRC400/T/UVC/H/970 /E40 TU	KRC400/T/UVC/VBU/960/E40 TU	KRC400/D/VBU/960/E40
Nominell effekt [W]	400	400	400	400
Testet effekt [W]	380	370	370	370
Vektet energiforbruk [kWh/1000 hrs]	418.43	405	404.76	405.66
Spenning [V]	118	130	115	115
Sokkel	E40	E40	E40	E40
Nominell lysytelse [lm]	28400	26000	27000	25400
Testet lysytelse [lm]	27000	25000	25000	23500
Lysutbytte [lm/W]	71	70	68	64
Energieffektivitetsklasse [EEC]	A	A	A	A
CCT [K]	6000	7500	6000	6000
CRI [Ra]	90	92	82	90
Kvikksølvinnehald [mg]	13	13.8	13	13
Omgivelsestemperatur [°C]	25	25	25	25
Levetid (vertikal) [t]	-	-	14,000	14,000
Levetid (horisontal) [t]	14,000	14,000	-	-
Brennstilling	HOR±45°	HOR±45°	VBU±45°	VBU±45°
Minimum starttemperatur [°C]	-20	-20	-20	-20

\* For optimal ytelse er ±15° anbefalt

\*\* ikke for EU

## Dimensjoner

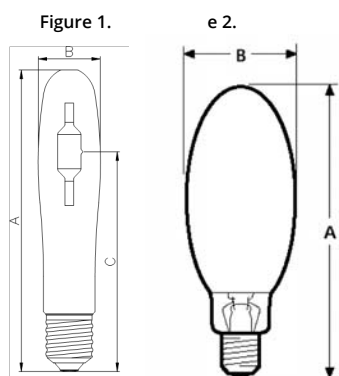

Produkt kode	A Lengde [mm]	B Diameter [mm]	C LCL [mm]	Sokkel	Brennstilling	Kolbeglass	Vekt [g]	Figure no.
93102172**	270	58	175	E40	HOR $\pm$ 45°	Hard glass	170	1
93102246	270	58	175	E40	HOR $\pm$ 45°	Hard glass	180	1
93102177**	270	58	175	E40	VBU $\pm$ 45°	Hard glass	170	1
93102161**	282	121	187	E40	VBU $\pm$ 45°	Hard glass	270	2

## Overlevelsesandel og opprettholdelse av lysytelse

Grafene viser andel overlevende av en representativ mengde lyskilder brukt under kontrollerte forhold ved 10 timers start. Lyskildelevetid i praksis vil være påvirket av flere parametre, slik som nettspenningsvariasjoner, tennsyklus, armaturdesign og forkobling. Informasjonen presentert er ment som praktisk informasjon for å avgjøre serviceintervall.

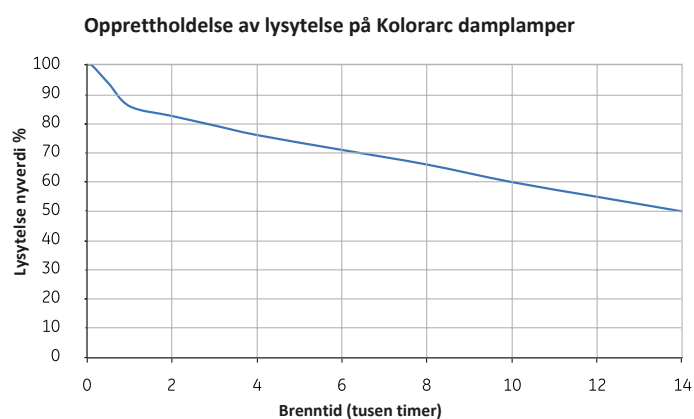
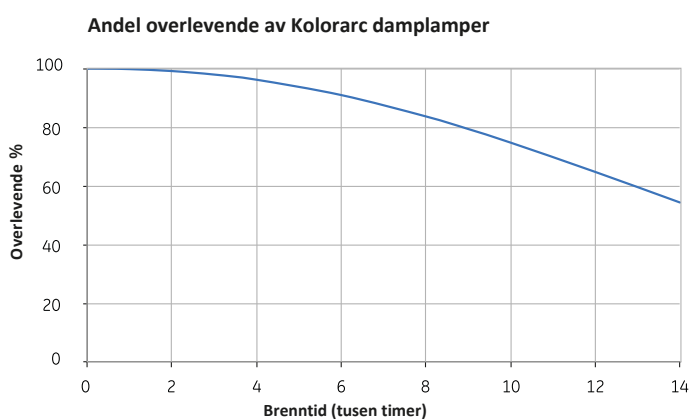

## Spektral effektfordeling

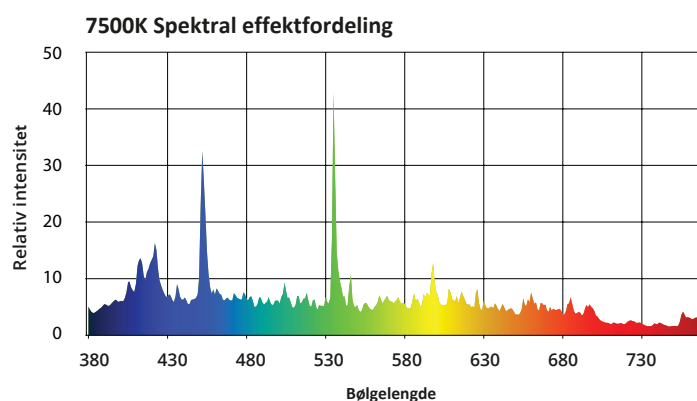
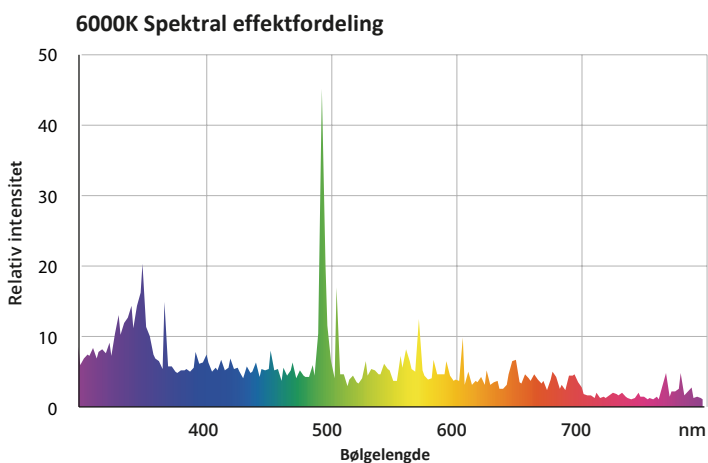

## Operating note

All metal halide lamps operate with a high internal pressure and there is a slight risk that lamps may shatter, particularly if run beyond rated life. At end of life a switch off should be introduced every 24 hours to reduce the risk of shattering. The lamp must be fully enclosed by a luminaire to ensure the retention of any fragments in the event of such failure.

## Electrical data

Data is based on a nominal lamp operating from a nominal choke (reactor) ballast with power factor correction. Supply power will be based on the characteristics of the commercially available metal halide ballast rated 3.5A, and metal halide ignitor.

Nominal wattage	Colour	Lamp Power [W]	Volts	Current [A]	Maximum Current Crest Factor
400	960	380	118±12	3.5	1.8
400	970	370	130±15	3.3	1.8

## Run-up characteristics

Time for the light output to reach 90% of the value is determined by supply voltage and ballast design. Typical value is three minutes.

## Hot re-strike time

All ratings re-strike within 10 minutes following a short interruption in the supply. Hot re-strike may be achieved using a suitable ignitor. Actual re-strike time is determined by ignitor type, pulse voltage and cooling rate of the lamp.

## Supply voltage

Lamps are suitable for supplies in the range 220V to 250V 50/60Hz for appropriately rated series choke (reactor) ballasts. Supplies outside this range require a transformer (conventional, high reactance or CWA) to ensure correct lamp operation. Lamps start and operate at 10% below the rated supply voltage when the correct control gear is used. However, in order to maximise lamp survival, lumen maintenance and colour uniformity the supply voltage and ballast design voltage should be within  $\pm 3\%$ . Supply variations of  $\pm 5\%$  are permissible for short periods only. This may be achieved by measuring mean supply voltage at the installation and selecting ballasts with appropriate settings.

## Control gear

It is therefore important to check the compatibility of lamp and control gear. Detailed information is given under "Guidance for Luminaire Manufacturers" overleaf. It is essential to use a ballast appropriate to the supply voltage at the luminaire. Typical wiring diagrams for control circuits incorporating "Superimposed" or "Impulser" ignitor and choke (reactor) ballast are shown. Refer to actual choke and ignitor manufacturers data for terminal identification and wiring information.

Typical run-up characteristics

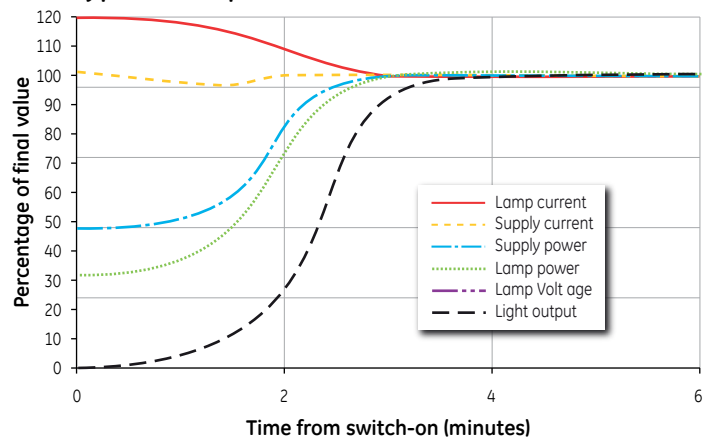

Effect of supply voltage variation

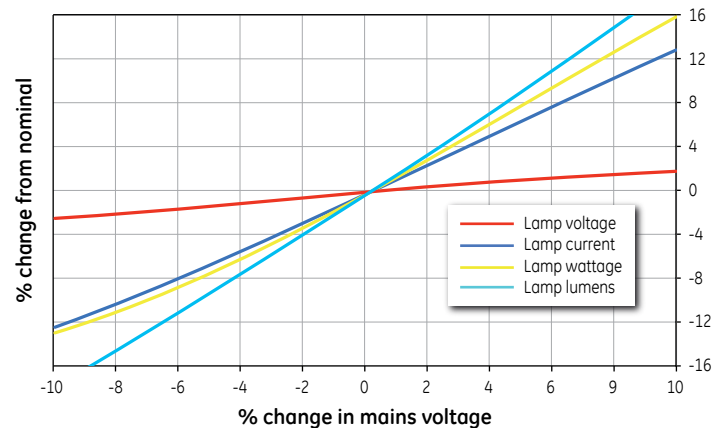

Typical superimposed ignitor circuit

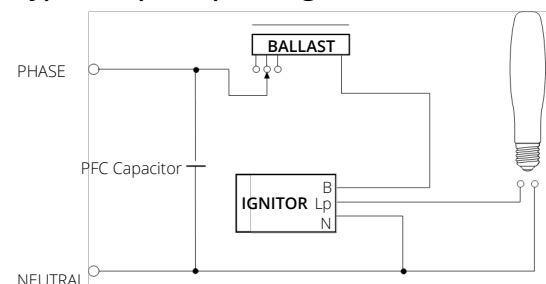

## Fusing of circuits

For a very short period after switch-on, all discharge lamps may act as a partial rectifier and as a result the ballast may allow several times the normal supply current to flow. To avoid nuisance fuse failure the ratings shown below should be used. Single fusing is recommended; MCB (type 3 or 4) or HBC fuse ratings.

## Guidance for luminaire manufacturers

### Lamp operating temperature limits

Wattage	Maximum Cap Temperature [°C]	Maximum Bulb Temperature [°C]
400	250	400

### Control gear

To achieve correct lamp starting, performance and life it is important that lamp and control gear are compatible and suitable rated for the supply voltage at the luminaire.

### Ballasts

Lamps are fully compatible with ballasts manufactured for metal halide lamps to IEC61167.

Ballasts should comply with specification IEC61347-1.

### Ballast thermal protection

Use of ballasts incorporating thermal cut-out is not a specific requirement but is a good optional safety measure for the installation.

### Ballast voltage adjustment

Series choke (reactor) ballasts incorporating additional tapings at  $\pm 10V$  of the rated supply voltage are recommended. Alternatively a single additional tapping 10V above the rated supply voltage will ensure lamps are not overloaded due to excessive supply voltage.

### Ignitors

Both Superimposed and Impulser type ignitors are suitable. It is recommended that only Tungfram approved ignitors are used. Ignitors should comply with specifications IEC61347-2 and IEC60927 and have starting pulse characteristics.

### Typical impulser ignitor circuit

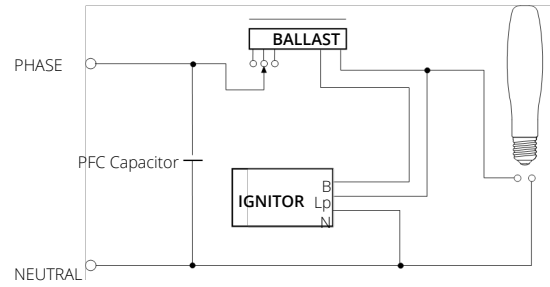

### Timed ignitors

Use of a "timed" or "cut-out" ignitor is not a specific requirement, but it is a good optional safety feature for the installation. The timed period must be adequate to allow lamps to cool and restart when the supply is interrupted briefly (see "Hot re-strike time"). A period of 5 minutes continuous or intermittent operation is recommended before the ignitor is automatically switched off. Commercially available 10/11 minute timed ignitors are suitable.

### Cable between ignitor and lamp

Cable connected between the lamp and a superimposed ignitor "Lp" terminal, or the ballast when using an impulser ignitor, must be rated at a minimum 50/60Hz voltage of 1000V. Mineral insulated cable is not suitable for connecting the lamp to the control gear.

To achieve good starting superimposed ignitors must be adjacent to the luminaire. Cable capacitance of wiring between the ignitor "Lp" terminal and the lamp should not exceed 100pF (<1 metre length) when measured to adjacent earthed metal and/or other cables, unless otherwise stated by the ignitor manufacturer.

When using impulser type ignitors longer cable lengths between ballast and lamp are normally permissible. Limits for particular ignitors are available on request from Tungfram or directly from the ignitor manufacturer.

### PFC capacitors for choke (reactor) circuits

Power Factor Correction is advisable in order to minimise supply current and electricity costs. For 220-250V supplies min. 250V rated capacitors are recommended.