



## Variable Frequency Drive, 1-/3- 230 V, 2.3 A, 0.37 kW, EMC-Filter



Powering Business Worldwide™

**Part no.** DC1-122D3FN-A20N  
**Article no.** 169240  
**Catalog No.** DC1-122D3FN-A20N

## Technical data

### General

Standards			Specification for general requirements: IEC/EN 61800-2 EMC requirements: IEC/EN 61800-3 Safety requirements: IEC/EN 61800-5-1
Certifications			CE, UL, cUL, c-Tick, UkrSepco, EAC
Production quality			RoHS, ISO 9001
Climatic proofing	$\rho_w$	%	< 95%, average relative humidity (RH), non-condensing, non-corrosive
Ambient temperature			
operation (150 % overload)	$\theta$	°C	-10 - +50
Storage	$\theta$	°C	-40 - +60
Radio interference level			
Radio interference class (EMC)			C1, C2, C3, depending on the motor cable length, the connected load, and ambient conditions. External radio interference suppression filters (optional) may be necessary.
Environment (EMC)			1st and 2nd environments as per EN 61800-3
maximum motor cable length	$l$	m	C1 ≤ 1 m C2 ≤ 5 m C3 ≤ 25 m
Mounting position			Vertical
Altitude		m	0 - 1000 m above sea level Above 1000 m: 1% derating for every 100 m max. 4000 m
Degree of Protection			IP20/NEMA 0
Protection against direct contact			BGV A3 (VBG4, finger- and back-of-hand proof)

### Main circuit

Supply			
Rated operational voltage	$U_e$		230 V AC, 1-phase 240 V AC, single-phase
Mains voltage (50/60Hz)	$U_{LN}$	V	200 (-10%) - 240 (+10%)
Input current (150% overload)	$I_{LN}$	A	3.7
System configuration			AC supply systems with earthed center point
Supply frequency	$f_{LN}$	Hz	50/60
Frequency range	$f_{LN}$	Hz	48 - 62
Mains switch-on frequency			Maximum of one time every 30 seconds
Power section			
Function			Frequency inverter with internal DC link and IGBT inverter
Overload current (150% overload)	$I_L$	A	3.45
max. starting current (High Overload)	$I_H$	%	175
Note about max. starting current			for 2 seconds every 20 seconds
Output voltage with $V_e$	$U_2$		230 V AC, 3-phase 240 V AC, 3-phase
Output Frequency	$f_2$	Hz	0 - 50/60 (max. 500)
Switching frequency	$f_{PWM}$	kHz	16 adjustable 4 - 32 (audible)
Operation Mode			U/f control Speed control with slip compensation
Frequency resolution (setpoint value)	$\Delta f$	Hz	0.1
Rated operational current			
At 150% overload	$I_e$	A	2.3
Note			Rated operational current at an operating frequency of 16 kHz and an ambient air temperature of +50 °C

Power loss			
Heat dissipation at rated operational current $I_{\theta} = 150\%$	$P_V$	W	18.5
Efficiency	$\eta$	%	95
Maximum leakage current to ground (PE) without motor	$I_{PE}$	mA	2.49
Fitted with			Radio interference suppression filter 7-digital display assembly
Frame size			FS1
Motor feeder			
Note			for normal internally and externally ventilated 4 pole, three-phase asynchronous motors with $1500 \text{ rpm}^{-1}$ at 50 Hz or $1800 \text{ min}^{-1}$ at 60 Hz
Note			Overload cycle for 60 s every 600 s
Note			at 230 V, 50 Hz
150 % Overload	P	kW	0.37
Note			at 220 - 240 V, 60 Hz
150 % Overload	P	HP	0.5
maximum permissible cable length	l	m	screened: 50 screened, with motor choke: 100 unscreened: 75 unscreened, with motor choke: 150
Apparent power			
Apparent power at rated operation 230 V	S	kVA	0.92
Apparent power at rated operation 240 V	S	kVA	0.96
Braking function			
Standard braking torque			max. 30 % $M_N$
DC braking torque			adjustable to 100 %

### Control section

Reference voltage	$U_S$	V	10 V DC (max. 10 mA)
Analog inputs			2, parameterizable, 0 - 10 V DC, 0/4 - 20 mA
Analog outputs			1, parameterizable, 0 - 10 V
Digital inputs			4, parameterizable, max. 30 V DC
Digital outputs			1, parameterizable, 24 V DC
Relay outputs			1, parameterizable, N/O, 6 A (250 V, AC-1) / 5 A (30 V, DC-1)
Interface/field bus (built-in)			OP-Bus (RS485)/Modbus RTU, CANopen <sup>®</sup>

### Assigned switching and protective elements

Power Wiring			
IEC (Type B, gG), 150 %			FAZ-B10/1N
UL (Class CC or J)		A	10
150 % overload (CT/ $I_H$ , at 50 °C)			DX-LN1-006
Motor feeder			
150 % overload (CT/ $I_H$ , at 50 °C)			DX-LM3-005
150 % overload (CT/ $I_H$ , at 50 °C)			DX-SIN3-004

### Design verification as per IEC/EN 61439

Technical data for design verification			
Rated operational current for specified heat dissipation	$I_n$	A	2.3
Heat dissipation per pole, current-dependent	$P_{vid}$	W	0
Equipment heat dissipation, current-dependent	$P_{vid}$	W	18.5
Static heat dissipation, non-current-dependent	$P_{vs}$	W	0
Heat dissipation capacity	$P_{diss}$	W	0
Operating ambient temperature min.		°C	-10
Operating ambient temperature max.		°C	50
IEC/EN 61439 design verification			
10.2 Strength of materials and parts			
10.2.2 Corrosion resistance			Meets the product standard's requirements.
10.2.3.1 Verification of thermal stability of enclosures			Meets the product standard's requirements.
10.2.3.2 Verification of resistance of insulating materials to normal heat			Meets the product standard's requirements.

10.2.3.3 Verification of resistance of insulating materials to abnormal heat and fire due to internal electric effects		Meets the product standard's requirements.
10.2.4 Resistance to ultra-violet (UV) radiation		Meets the product standard's requirements.
10.2.5 Lifting		Does not apply, since the entire switchgear needs to be evaluated.
10.2.6 Mechanical impact		Does not apply, since the entire switchgear needs to be evaluated.
10.2.7 Inscriptions		Meets the product standard's requirements.
10.3 Degree of protection of ASSEMBLIES		Does not apply, since the entire switchgear needs to be evaluated.
10.4 Clearances and creepage distances		Meets the product standard's requirements.
10.5 Protection against electric shock		Does not apply, since the entire switchgear needs to be evaluated.
10.6 Incorporation of switching devices and components		Does not apply, since the entire switchgear needs to be evaluated.
10.7 Internal electrical circuits and connections		Is the panel builder's responsibility.
10.8 Connections for external conductors		Is the panel builder's responsibility.
10.9 Insulation properties		
10.9.2 Power-frequency electric strength		Is the panel builder's responsibility.
10.9.3 Impulse withstand voltage		Is the panel builder's responsibility.
10.9.4 Testing of enclosures made of insulating material		Is the panel builder's responsibility.
10.10 Temperature rise		The panel builder is responsible for the temperature rise calculation. Eaton will provide heat dissipation data for the devices.
10.11 Short-circuit rating		Is the panel builder's responsibility. The specifications for the switchgear must be observed.
10.12 Electromagnetic compatibility		Is the panel builder's responsibility. The specifications for the switchgear must be observed.
10.13 Mechanical function		The device meets the requirements, provided the information in the instruction leaflet (IL) is observed.

## Technical data ETIM 6.0

Low-voltage industrial components (EG000017) / Frequency converter =< 1 kV (EC001857)		
Electric engineering, automation, process control engineering / Electrical drive / Static frequency converter / Static frequency converter = < 1 kv (ecl@ss8.1-27-02-31-01 [AKE177011])		
Mains voltage	V	200 - 240
Mains frequency		50/60 Hz
Number of phases input		1
Number of phases output		3
Max. output frequency	Hz	500
Max. output voltage	V	230
Rated output current I2N	A	2.3
Max. output at quadratic load at rated output voltage	kW	0.37
Max. output at linear load at rated output voltage	kW	0.37
With control unit		Yes
Application in industrial area permitted		Yes
Application in domestic- and commercial area permitted		Yes
Supporting protocol for TCP/IP		No
Supporting protocol for PROFIBUS		No
Supporting protocol for CAN		Yes
Supporting protocol for INTERBUS		No
Supporting protocol for ASI		No
Supporting protocol for KNX		No
Supporting protocol for MODBUS		Yes
Supporting protocol for Data-Highway		No
Supporting protocol for DeviceNet		No
Supporting protocol for SUCONET		No
Supporting protocol for LON		No
Supporting protocol for PROFINET IO		No
Supporting protocol for PROFINET CBA		No
Supporting protocol for SERCOS		No
Supporting protocol for Foundation Fieldbus		No
Supporting protocol for EtherNet/IP		No
Supporting protocol for AS-Interface Safety at Work		No

Supporting protocol for DeviceNet Safety			No
Supporting protocol for INTERBUS-Safety			No
Supporting protocol for PROFIsafe			No
Supporting protocol for SafetyBUS p			No
Supporting protocol for other bus systems			No
Number of HW-interfaces industrial Ethernet			0
Number of HW-interfaces PROFINET			0
Number of HW-interfaces RS-232			0
Number of HW-interfaces RS-422			0
Number of HW-interfaces RS-485			1
Number of HW-interfaces serial TTY			0
Number of HW-interfaces USB			1
Number of HW-interfaces parallel			0
Number of HW-interfaces other			0
With optical interface			No
With PC connection			Yes
Integrated breaking resistance			No
4-quadrant operation possible			No
Type of converter			U converter
Degree of protection (IP)			IP20
Height		mm	184
Width		mm	81
Depth		mm	124
Relative symmetric net frequency tolerance		%	10
Relative symmetric net current tolerance		%	10

## Approvals

Product Standards			UL 508C; CSA-C22.2 No. 14; IEC/EN61800-3; IEC/EN61800-5; CE marking
UL File No.			E172143
UL Category Control No.			NMMS, NMMS7
CSA File No.			UL report applies to both US and Canada
North America Certification			UL listed, certified by UL for use in Canada
Specially designed for North America			No
Suitable for			Branch circuits
Max. Voltage Rating			1~ 240 V AC IEC: TN-S UL/CSA: "Y" (Solidly Grounded Wey)
Degree of Protection			IEC: IP20

## Dimensions

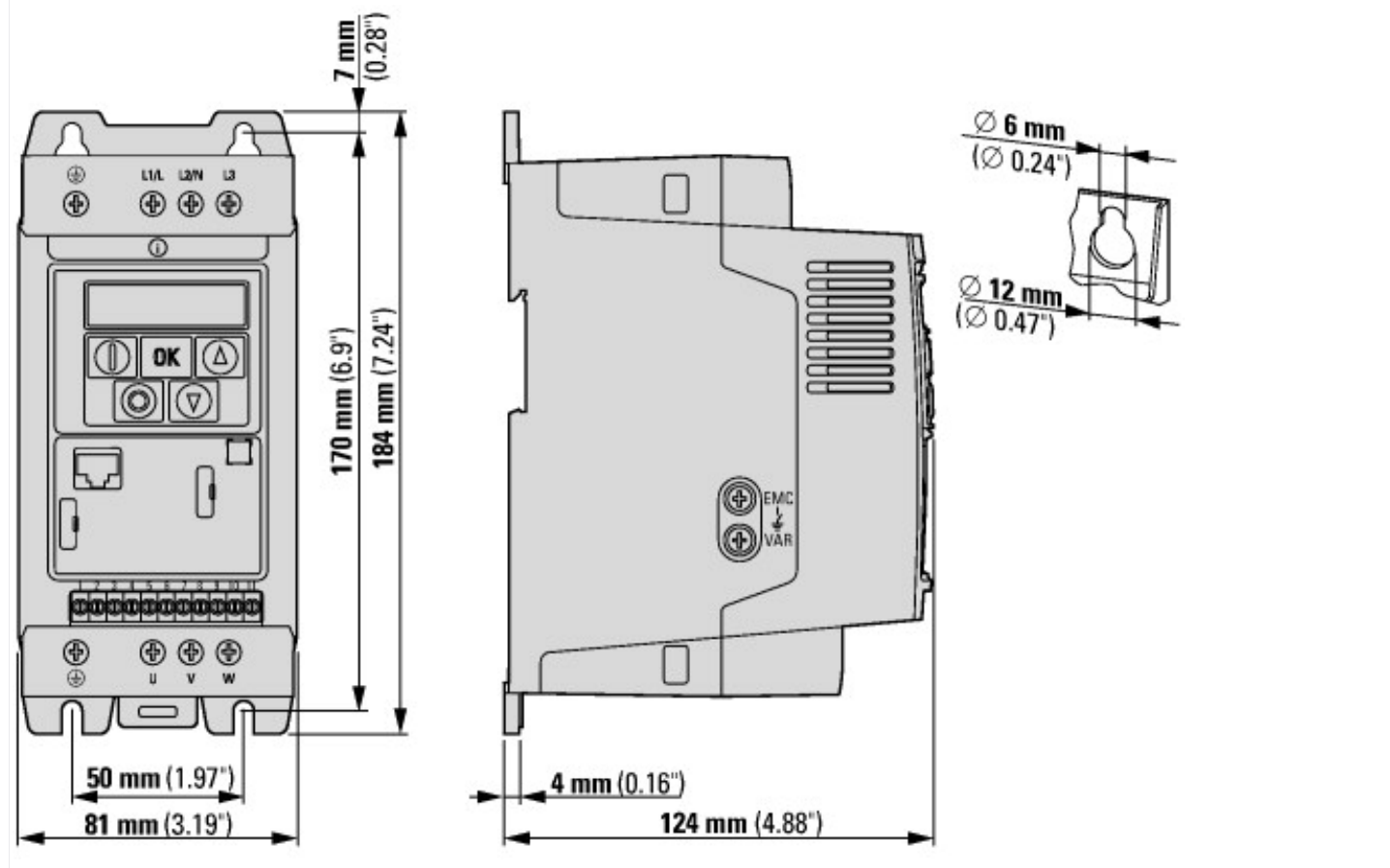

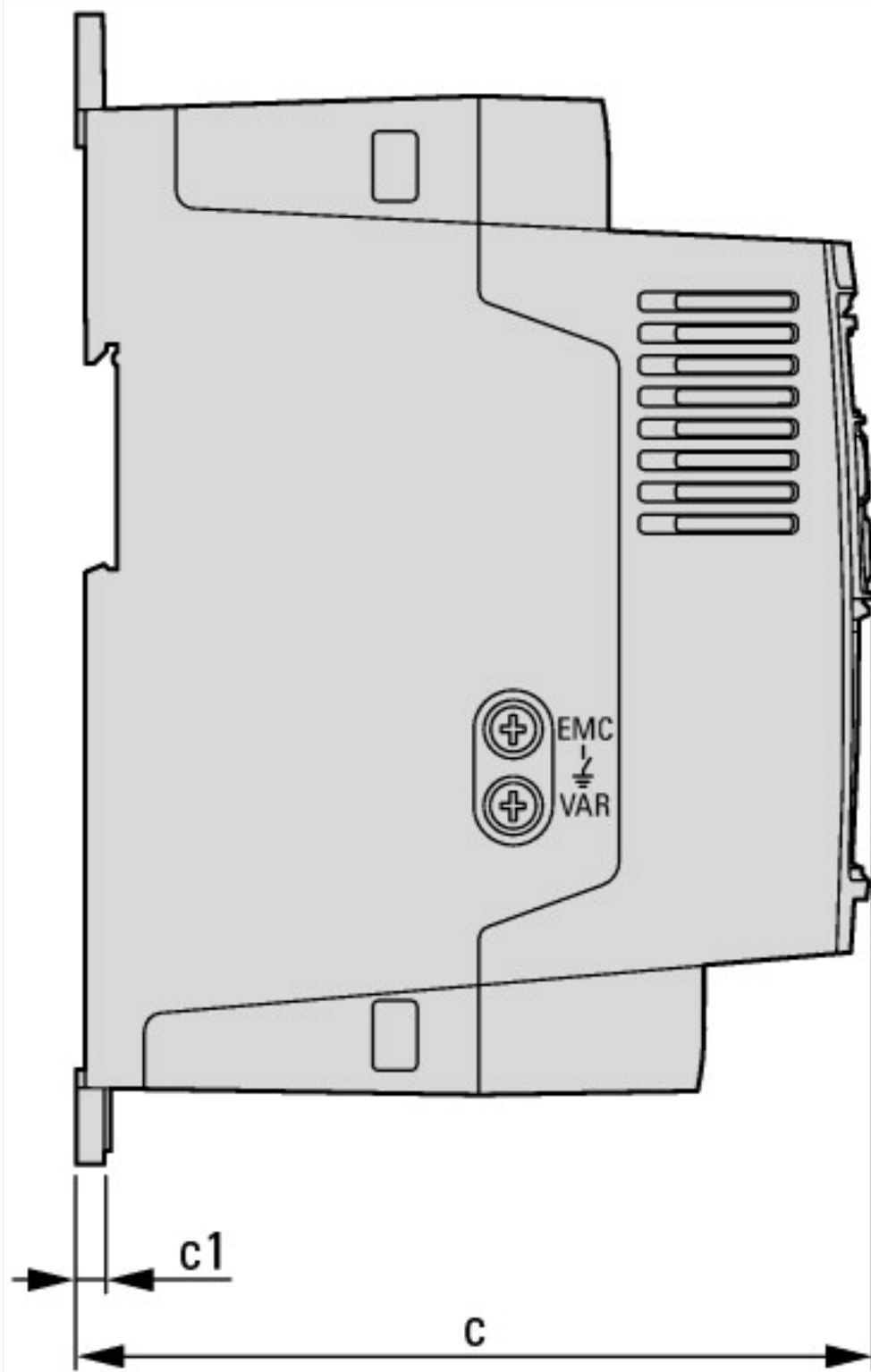

## Additional product information (links)

### IL04020009Z DC1 variable frequency drives (FS1 - FS3, IP20)

IL04020009Z DC1 variable frequency drives (FS1 - FS3, IP20) [ftp://ftp.moeller.net/DOCUMENTATION/AWA\\_INSTRUCTIONS/IL04020009Z2016\\_07.pdf](ftp://ftp.moeller.net/DOCUMENTATION/AWA_INSTRUCTIONS/IL04020009Z2016_07.pdf)

### MN04020003Z DC1 variable frequency drives, Installation manual

MN04020003Z Frequenzumrichter DC1, Handbuch - Deutsch [ftp://ftp.moeller.net/DOCUMENTATION/AWB\\_MANUALS/MN04020003Z\\_DE.pdf](ftp://ftp.moeller.net/DOCUMENTATION/AWB_MANUALS/MN04020003Z_DE.pdf)

MN04020003Z DC1 variable frequency drive, manual - English [ftp://ftp.moeller.net/DOCUMENTATION/AWB\\_MANUALS/MN04020003Z\\_EN.pdf](ftp://ftp.moeller.net/DOCUMENTATION/AWB_MANUALS/MN04020003Z_EN.pdf)

MN04020003Z Frekvenční měnič DC1, manuál - čeština [ftp://ftp.moeller.net/DOCUMENTATION/AWB\\_MANUALS/MN04020003Z\\_CZ.pdf](ftp://ftp.moeller.net/DOCUMENTATION/AWB_MANUALS/MN04020003Z_CZ.pdf)

MN04020003Z Convertitori di frequenza DC1, manuale - italiano [ftp://ftp.moeller.net/DOCUMENTATION/AWB\\_MANUALS/MN04020003Z\\_IT.pdf](ftp://ftp.moeller.net/DOCUMENTATION/AWB_MANUALS/MN04020003Z_IT.pdf)

### MN04020004Z DC1 variable frequency drives, Parameters manual

MN04020004Z DC1 variable frequency drives, Parameters manual - Deutsch [ftp://ftp.moeller.net/DOCUMENTATION/AWB\\_MANUALS/MN04020004Z\\_DE.pdf](ftp://ftp.moeller.net/DOCUMENTATION/AWB_MANUALS/MN04020004Z_DE.pdf)

MN04020004Z DC1 variable frequency drives,  
Parameters manual - English

[ftp://ftp.moeller.net/DOCUMENTATION/AWB\\_MANUALS/MN04020004Z\\_EN.pdf](ftp://ftp.moeller.net/DOCUMENTATION/AWB_MANUALS/MN04020004Z_EN.pdf)

CA04020001Z-DE Sortimentskatalog:  
Antriebstechnik effizient gestalten, Motoren  
starten und steuern

[http://www.eaton.eu/DE/ecm/groups/public/@pub/@europe/@electrical/documents/content/pct\\_1095238\\_de.pdf](http://www.eaton.eu/DE/ecm/groups/public/@pub/@europe/@electrical/documents/content/pct_1095238_de.pdf)