



METRIC
INDUSTRIAL

FibreCore UWIC Enkelarmert sjøkabel



FibreCore UWIC er en sjøkabel med ett lag med galvanisert ståltrådarmering og med ytre kappe av slitesterk polyetylen. Kabelen leveres med 12 til 288 G.652D fibre som er merket i henhold til Telenor farge kode. Kabelen egner seg for forlegning i grunne innsjøer, vassdrag eller i grunne farvann langs kysten.

1. GENERAL

1.1 Scope

The listed specifications covers the design requirements and performance standard for the supply of optical fiber cable in the industry. It also includes this premium designed cable with optical, mechanical and geometrical characteristics.

Cable marking	Application
FibreCore-xxx G.652D-FSwUW-S1	Under water installation cable

xxx: Fiber count

1.2 Cable Description

The cable possesses high tensile strength and flexibility in a compact cable size. At the same time, it provides excellent optical transmission and physical performance.

1.3 Quality

Excellent quality control is achieved through intense in-house quality check and stringent audit acceptance by ISO 9001.

1.4 Reliability

Initial and periodic product qualification tests for performance and durability are performed rigorously to ensure product reliability.

1.5 Reference

The cable offered are designed, manufactured and tested according international standards as follows:

IEC 60793-1	Optical fiber Part 1: Generic specifications
IEC 60793-2	Optical fiber part2: Product specifications
IEC 60794-3-30	Optical fiber cables: Part 3-30, outdoor cables- family specification for lake and river crossings
ITU-T G.650	Definition and test methods for the relevant parameters of single-mode fibers
ITU-T G.652	Characteristics of a single-mode optical fiber and cable

2. OPTICAL FIBER

The optical fiber is made of high pure silica and germanium doped silica. UV curable acrylate material is applied over fiber cladding as optical fiber fiber primary protective coating. The detail data of optical fiber performance are shown in the following table. ITU-T G652 fiber uses special spun device to successfully control the value of PMD to ensure stability during cabling.

G.652D Fiber

Category	Description	Specifications	
		Before cabling	After cabling
Optical Specifications	Attenuation @ 1310 nm	≤0,34 dB/km	≤0,36 dB/km
	Attenuation @ 1550 nm	≤0,20 dB/km	≤0,22 dB/km
	Zero Dispersion Wavelength	1300~1324 nm	
	Zero Dispersion Slope	≤0,092ps/nm ² -km	
	PMD Max. Value	≤0,2 ps/√km	
	Cable Cutoff Wavelength (λ)	≤1260 nm	
	Macro bending loss		
	(100 turns ø50 mm) @ 1550 nm	≤0,05 dB	
	(100 turns ø50 mm) @ 1625 nm	≤0,10 dB	
	MDF (Mode Field Diameter) @ 1310 nm	9,2 ± 1μm	
Dimensional Specifications	Cladding Diameter	125 ± 1μm	
	Core/clad concentricity error	≤0,6μm	
	Cladding non-circularity	≤1,0%	
Mechanical Specifications	Proof stress	≥0,69Gpa	

3. CABLE STRUCTURE

3.1 Cable type

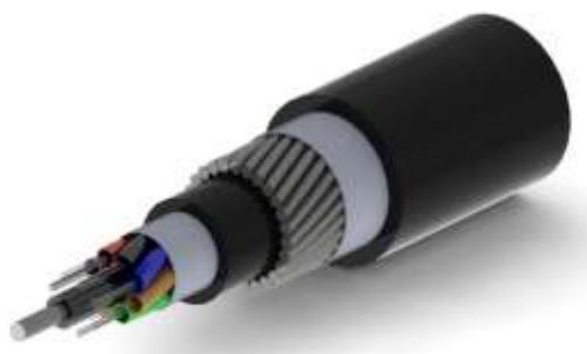
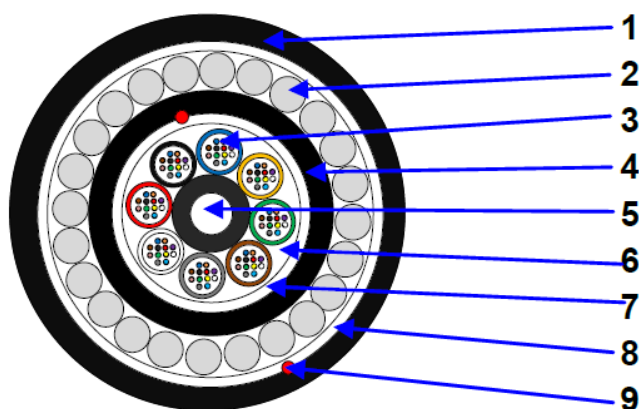

Bildet er kun for referanse

Construction:

- | | | |
|------------------------|---|--------------------------------|
| 1. Outer sheath (HDPE) | 2. Galvanized steel wire armor | 3. Loose tube, fiber and jelly |
| 4. Inner sheath (HDPE) | 5. Central strength member (Coated FRP) | 6. Thixotropic jelly |
| 7. Water blocking tape | 8. Wrap tape | 9. Ripcord x2 |

Technical Characteristics:

- The unique extruding technology provides the fibers in the tube with good flexibility and bending endurance
- The unique fiber excess length control method provides the cable with excellent mechanical and environmental properties
- Multiple water blocking material fillings provides dual water blocking function

Dimension and Properties

Fiber count	12	24	48	96	144	192	240	288
No. of loose tube/filler layer 1	1/5	2/4	4/2	8/0	12/0	6/0	9/0	9/0
No. of loose tube/filler layer 2	-	-	-	-	-	10/2	11/4	15/0
Fiber no. per tube	12							
Cable OD, nominell (mm)	14,5	14,5	14,5	15,7	18,9	20,0	21,2	21,2
Cable weight, nominell (kg/km)	400	403	405	445	630	815	870	875
Operation temp. range (°C)	-40 ~+70							
Installation temp. range (°C)	-20 ~+70							
Transport/storage temp. range (°C)	-40 ~+70							
Max.tensile load (N)	5000							
Crush resistance (N/10cm)	Short term: 5000, Long term: 2000							
Minimum installation bending radius	30 x OD							
Minimum operational bending radius	15 x OD							

COLOR CODE SCHEME

Color code fiber

1 Hvit	2 Rød	3 Gul	4 Grønn	5 Blå	6 Grå	7 Brun	8 Sort	9 Violett	10 Aqua	11 Orange	12 Rosa

Color code tube layer 1 (inner layer)

1 Hvit	2 Rød	3 Gul	4 Grønn	5 Blå	6 Grå	7 Brun	8 Sort	9 Violett	10 Aqua	11 Orange	12 Rosa

Color code tube layer 2 (outer layer)

1 Hvit	2 Rød	3 Gul	4 Grønn	5 Blå	6 Grå	7 Brun	8 Sort	9 Violett	10 Aqua	11 Orange	12 Rosa
13 Aqua	14 Orange	15 Rosa									

Other color code scheme are available on request.

4. TEST REQUIREMENT

The cable is in accordance with applicable standard of cable and requirement of customer. The following test items are carried out according to corresponding reference.

Mode field diameter	IEC 60793-1-45
Core/clad concentricity	IEC 60793-1-20
Cladding diameter	IEC 60793-1-20
Cladding non-circularity	IEC 60793-1-20
Attenuation coefficient	IEC 60793-1-40
Chromatic dispersion	IEC 60793-1-42
Cable cut-off wavelength	IEC 60793-1-44

TEST LIST

4.1 Tension Loading Test

Test Standard	IEC 60794-1-2 E1
Sample length	No less than 50 mtr.
Load	Max. Tension load
Duration time	10 min.
Test result	Fiber strain $\leq 0,33\%$
	Additional attenuation $\leq 0,1\text{dB}$
	No damage to outer jacket nor inner elements

4.2 Crush/Compression Test

Test Standard	IEC 60794-1-2 E3
Load	Crush load
Duration time	5 min.
Test number	3
Test result	Additional attenuation $\leq 0,1\text{dB}$
	No damage to outer jacket nor inner elements

4.3 Impact Resistance Test

Test Standard	IEC 60794-1-2 E4
Impact energy	10J
Radius	300mm
Impact points	3
Impact numbers	1
Test result	Additional attenuation $\leq 0,1\text{dB}$
	No damage to outer jacket nor inner elements

4.4 Temperature Cycling Test

Test Standard	IEC 60794-1-2 F1
Impact energy	+20°C -> -40°C -> +70°C -> -40°C -> +70°C -> +20°C
Radius	12 hrs
Impact points	2
Test result	After test, attenuation variation for reference value (the attenuation to be measured before test at +20±3°C) $\leq 0,10\text{dB/km}$ at 1550 nm

4.5 Water Penetration Test

Test Standard	IEC 60794-1-2 F5B
Height of water column	1 mtr.
Sample length	3 mtr.
Test time	24 hrs
Test result	No water leakage from the opposite of the cable core

4.6 Drip Test

Test Standard	IEC 60794-1-2 E14
Sample length	0,3 mtr.
Temperature	70°C
Duration	24 hrs
Test result	No filling compound shall drip from the tubes

5. PACKAGING AND DRUM

5.1 The cables are coiled on Iron-wooden drum. During transportation, the correct tools should be used to avoid damaging the package and to handle with ease. Cables should be protected from moisture, kept away from high temperature and fire sparks. It should be protected from over bending and crushing as well as from mechanical stress and damage.

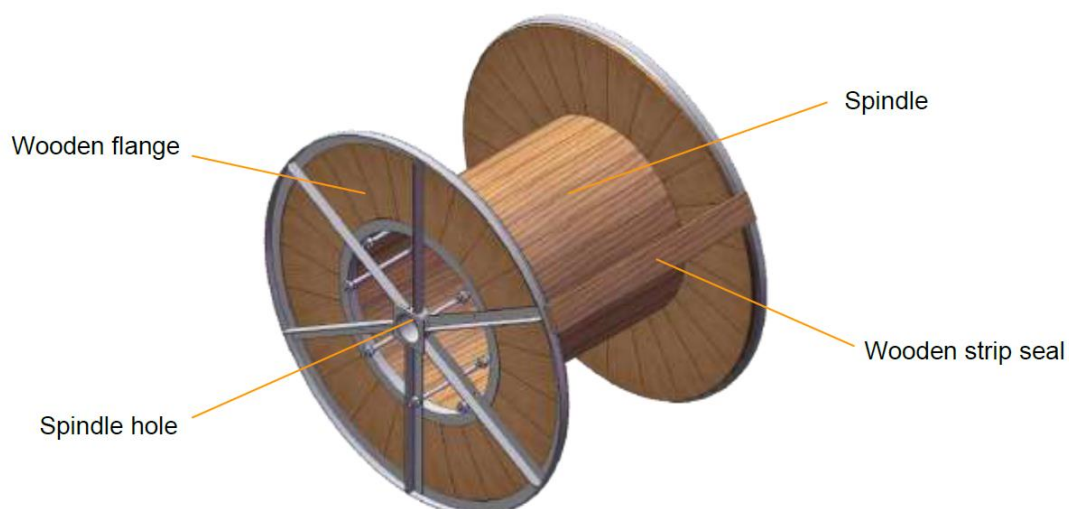

5.2 The color of cable marking is white (The printing shall be carried out at interval of 1 meter on the outer sheath of the cable) The inner end of the cable is then sealed with heat shrinkable end cap to prevent ingress of water and is made available for testing. The outer end of the cable is equipped with heat shrinkable end cap. Outer sheath marking legend can be changed upon user's request

5.3 Outdoor cable packing. Iron wooden drum. Strong wooden batten protection.

ORDERING INFORMATION

Elnr	MI art. Nr.	Beskrivelse
10 009 60	G12-9/125 B1.D UWIC 1S	G12 FibreCore UWIC enkelarmert sjøkabel, G.652D
10 009 61	G24-9/125 B1.D UWIC 1S	G24 FibreCore UWIC enkelarmert sjøkabel, G.652D
10 009 62	G48-9/125 B1.D UWIC 1S	G48 FibreCore UWIC enkelarmert sjøkabel, G.652D
10 009 63	G96-9/125 B1.D UWIC 1S	G96 FibreCore UWIC enkelarmert sjøkabel, G.652D
10 009 64	G144-9/125 B1.D UWIC 1S	G144 FibreCore UWIC enkelarmert sjøkabel, G.652D
10 009 65	G192-9/125 B1.D UWIC 1S	G192 FibreCore UWIC enkelarmert sjøkabel, G.652D
10 009 66	G240-9/125 B1.D UWIC 1S	G240 FibreCore UWIC enkelarmert sjøkabel, G.652D
10 009 67	G288-9/125 B1.D UWIC 1S	G288 FibreCore UWIC enkelarmert sjøkabel, G.652D